



Dough Mixers

Spiral Dough Kneader 33lt, 2 Speeds, Removable Bowl, Tilting Head

ITEM # _____

MODEL # _____

NAME # _____

SIS # _____

AIA # _____



602357 (DSKTH33L)

33 Lt spiral Dough Kneader,
2 speed Removable Bowl,
Tilting Head,
380-415v/3/50hz

Short Form Specification

Item No. _____

2 speed spiral dough kneader on wheels, with tilting head and motorized, removable bowl. Ideal for pizzeria, bakeries and pastries. Ingredients are kneaded with a stainless steel spiral mixer arm synchronised with bowl rotation (motorized not removable bowl). Body is in painted steel, the 33 lt capacity bowl, spiral mixer arm and dough breaker pin are in stainless steel. The safety screen allows ingredients to be added without stopping. Equipped with low voltage control panel with on/off switch, speed selection and timer (up to 30 min) or continuous mode. Safety device to stop the machine when the protection screen is opened. Tool speed: 84 and 168 rpm; bowl speed: 10 and 20 rpm. Maximum kneading capacity: 25 kg per cycle (max flour 15.6 kg/cycle), with 60% hydration.

Main Features

- Spiral dough kneader with tilting head and motorized, removable bowl.
- Ideal for kneading pizza dough, bread or similar dough.
- Two speed kneading for faster cycles (tool speed: 84 and 168 rpm; bowl speed: 10 and 20 rpm).
- Stainless steel (AISI304) squared dough breaker bar for fast and even kneading results
- Maximum kneading capacity: 25 kg per cycle (max flour 15.6 kg/cycle), with 60% hydration.
- Transparent protective screen to reduce flour dust release in the work area during kneading (EU EN453:2014) and to prevent dough contaminations.
- Minimum kneading capacity: 15 kg/cycle, with 60% hydration.
- Safety device stops the appliance if the cover is openend.
- Equipped with 4 wheels, of which 2 with brakes, allowing to easily move the appliance for storage or cleaning.
- The appliance fits under standard kitchen worktops (see installation drawing).

Construction

- Constructed in painted steel.
- AISI304 stainless steel bowl, spiral hook and dough breaker bar.
- Control panel with on/off switch, speed selection and timer.
- Analogic timer up to 30 minutes or continuous mode.
- IP54 protected control panel.
- IP23 for the appliance overall.
- Additional bowl available as optional accessory.

Included Accessories

- 1 of 33lt s/s bowl for PNC 653892
tilting head spiral
dough kneader

Optional Accessories

APPROVAL: _____



Dough Mixers Spiral Dough Kneader 33lt, 2 Speeds, Removable Bowl, Tilting Head

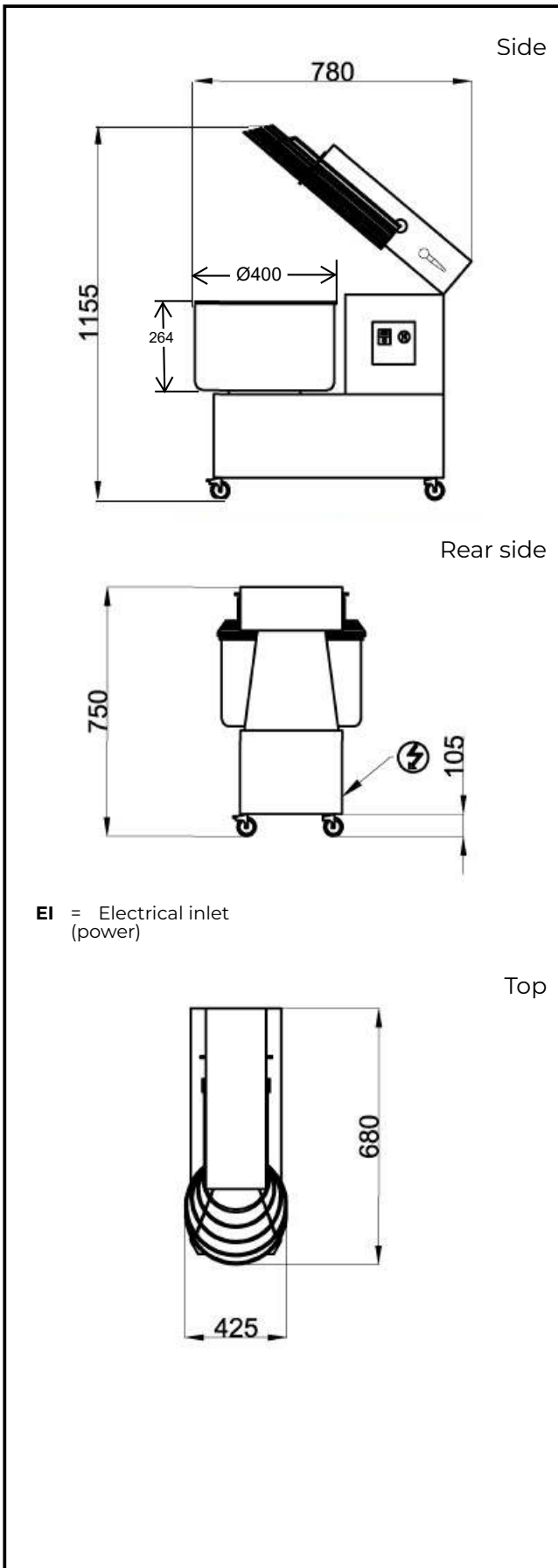

Electric

Supply voltage: 380-415 V/3 ph/50 Hz
Total Watts: 1.5 kW

Capacity:

Maximum kneading (60% hydration): 25 kg/Cycle

Key Information:

External dimensions, Width: 425 mm

External dimensions, Depth: 680 mm

External dimensions, Height: 750 mm

Shipping weight: 98 kg

Bowl capacity: 33 lt



Dough Mixers
Spiral Dough Kneader 33lt, 2 Speeds, Removable Bowl, Tilting Head
The company reserves the right to make modifications to the products
without prior notice. All information correct at time of printing.

2026.03.31